

Countertop Display



FCD07-105BA



FCD07-120BA



FCD07-160BA

Standard Features:

- Bright internal LED illumination on top
- Digital temperature controller and display
- Adjustable chrome plated shelves
- 4 sides double glass
- Front curved glass
- Sliding doors
- Maintenance free condenser
- Ventilated cooling system
- Automatic defrost
- Stainless steel



LED Lights



Adjustable Shelf



Digital Controller

FCD07-105BA		FCD07-120BA		FCD07-160BA	
Capacity-Gross (L)	100	Capacity-Gross (L)	120	Capacity-Gross (L)	160
Temperature Range (°C)	0-12	Temperature Range (°C)	0-12	Temperature Range (°C)	0-12
Rated Input Power (W)	160	Rated Input Power (W)	230/160	Rated Input Power (W)	230/160
Refrigerant	R134a/R600a	Refrigerant	R134a/R600a	Refrigerant	R134a/R600a
Type of Climate	N	Type of Climate	N	Type of Climate	N
N.W. (kg)	39.1	N.W.(kg)	64	N.W. (kg)	71
G.W. (kg)	42.5	G.W.(kg)	66	G.W. (kg)	73.5
Overall Dimension (mm)	682x450x675	Overall Dimension (mm)	696x568x686	Overall Dimension (mm)	874x568x686
Package Dimension (mm)	756x524x760	Package Dimension (mm)	773x627x735	Package Dimension (mm)	951x627x735
20"Container	90	20"Container	81	20"Container	63
40"Container	189	40"Container	162	40"Container	126
40"Container (high)	189	40"Container (high)	162	40"Container (high)	126

Countertop Display



FCD07-130BA1



FCD07-160BA2

Standard Features:

- Bright internal LED illumination on top
- Digital temperature controller and display
- Adjustable chrome plated shelves
- 4 sides double glass
- Sliding doors
- Ventilated cooling system
- Automatic defrost
- Stainless steel



LED Lights



Adjustable Shelf



Digital Controller

FCD07-130BA1

Capacity-Gross (L)	130
Temperature Range (°C)	0-12
Rated Input Power (W)	230/180
Refrigerant	R134a/R600a
Type of Climate	N
N.W. (kg)	63
G.W. (kg)	65
Overall Dimension (mm)	697x578x678
Package Dimension (mm)	773x627x735
20"Container	81
40"Container	162
40"Container (high)	162

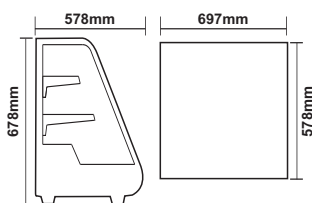

FCD07-160BA2

Capacity-Gross (L)	160
Temperature Range (°C)	0-12
Rated Input Power (W)	230/180
Refrigerant	R134a/R600a
Type of Climate	N
N.W. (kg)	67
G.W. (kg)	69
Overall Dimension (mm)	875x578x678
Package Dimension (mm)	951x627x735
20"Container	63
40"Container	126
40"Container (high)	126

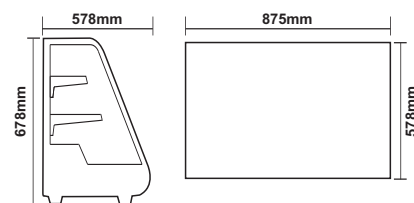

Countertop Display



FCD07-110BA

Standard Features:

- Bright internal LED illumination on top
- Digital temperature controller and display
- Non-adjustable chrome plated shelf
- 4 sides double glass
- Front Curved glass

FCD07-110BA

Capacity-Gross (L)	110
Temperature Range (°C)	2-10
Rated Input Power (W)	300
Refrigerant	R134a/R600A
Type of Climate	N
N.W. (kg)	64.8
G.W. (kg)	67
Overall Dimension (mm)	750x775x640
Package Dimension (mm)	840x810x671
20"Container	42
40"Container	84
40"Container (high)	84

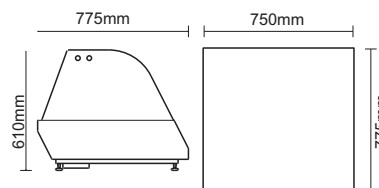

Cake Display Counter



FCD07-72BR

Standard Features:

- Bright internal LED illumination on 2 sides
- Digital temperature controller and display
- Fixed chrome plated shelves
- Round double glass
- Ventilated cooling system
- Automatic defrost

Options:

- Rotational chrome plated shelves

FCD07-72BR

Capacity-Gross (L)	72
Temperature Range (°C)	0-10
Rated Input Power (W)	170
Refrigerant	R134a/R600a
Type of Climate	N
N.W. (kg)	38.5
G.W. (kg)	41
Overall Dimension (mm)	450x450x983
Package Dimension (mm)	500x500x1050
20"Container	88
40"Container	184
40"Container (high)	184
Color	black

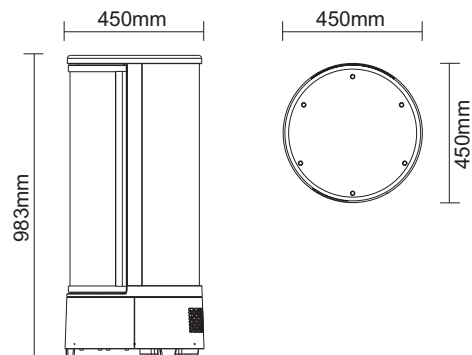

Flat Glass Door



Lightbox



FCD07-58V



FCD07-58V2



FCD07-68V



FCD07-68V2

Standard Features:

- Internal top LED light
- Adjustable temperature controller
- Adjustable PVC coated shelves
- 4 sides double glass
- Maintenance free condenser
- Ventilated cooling system
- Automatic defrost
- Digital temperature controller and display



Digital Controller



Lockable



LED Lights



Internal LED Light



Shelf Clips

Options:

- Lockable Door
- Adjustable chrome plated shelves
- Bright internal LED illumination on sides
- Light display box with decal on top

FCD07-58V		FCD07-58V2		FCD07-68V		FCD07-68V2	
Capacity-Gross (L)	58	Capacity-Gross (L)	58	Capacity-Gross (L)	68	Capacity-Gross (L)	68
Temperature Range (°C)	0-12	Temperature Range (°C)	0-12	Temperature Range (°C)	0-12	Temperature Range (°C)	0-12
Rated Input Power (W)	180	Rated Input Power (W)	180	Rated Input Power (W)	180	Rated Input Power (W)	180
Refrigerant	R134a/R600a	Refrigerant	R134a/R600a	Refrigerant	R134a/R600a	Refrigerant	R134a/R600a
Type of Climate	N	Type of Climate	N	Type of Climate	N	Type of Climate	N
N.W. (kg)	30	N.W. (kg)	31	N.W. (kg)	32.5	N.W. (kg)	33.5
G.W. (kg)	32	G.W. (kg)	33	G.W. (kg)	35	G.W. (kg)	36
Overall Dimension (mm)	428x386x810	Overall Dimension (mm)	428x386x925	Overall Dimension (mm)	428x386x885	Overall Dimension (mm)	428x386x1000
Package Dimension (mm)	475x432x888	Package Dimension (mm)	475x432x995	Package Dimension (mm)	475x432x993	Package Dimension (mm)	475x432x1070
20"Container	124	20"Container	124	20"Container	124	20"Container	124
40"Container	258	40"Container	258	40"Container	258	40"Container	258
40"Container (high)	258	40"Container (high)	258	40"Container (high)	258	40"Container (high)	258
Coior	white/black/silver/red	Coior	white/black/silver/red	Coior	white/black/silver/red	Coior	white/black/silver/red

Flat Glass Door



Lightbox



FCD07-78BV



FCD07-78BV2



FCD07-98BV

Standard Features:

- Internal top LED light
- Adjustable temperature controller
- Adjustable PVC coated shelves
- 4 sides double glass
- Maintenance free condenser
- Ventilated cooling system
- Automatic defrost
- Digital temperature controller and display



Digital Controller



Lockable



LED Lights



Internal LED Light



Shelf Clips

Options:

- Lockable Door
- Adjustable chrome plated shelves
- Bright internal LED illumination on sides
- Light display box with decal on top

FCD07-78BV		FCD07-78BV2		FCD07-98BV	
Capacity-Gross (L)	78	Capacity-Gross (L)	78	Capacity-Gross (L)	98
Temperature Range (°C)	0-12	Temperature Range (°C)	0-12	Temperature Range (°C)	0-12
Rated Input Power (W)	180	Rated Input Power (W)	180	Rated Input Power (W)	180
Refrigerant	R134a/R600a	Refrigerant	R134a/R600a	Refrigerant	R134a/R600a
Type of Climate	N	Type of Climate	N	Type of Climate	N
N.W. (kg)	33.8	N.W. (kg)	34.8	N.W. (kg)	38
G.W. (kg)	36.2	G.W. (kg)	37.2	G.W. (kg)	40.5
Overall Dimension (mm)	428x386x960	Overall Dimension (mm)	428x386x1075	Overall Dimension (mm)	428x386x1110
Package Dimension (mm)	475x432x1038	Package Dimension (mm)	475x432x1145	Package Dimension (mm)	475x432x1180
20" Container	124	20" Container	124	20" Container	62
40" Container	258	40" Container	258	40" Container	129
40" Container (high)	258	40" Container (high)	258	40" Container (high)	129
Color	white/black/silver/red	Color	white/black/silver/red	Color	white/black/silver/red

Flat Glass Door



FCD07-80V



FCD07-78BV8



FCD07-108BV



Adjustable feet



Digital Controller

Standard Features:

- Bright internal LED illumination on 2 sides
- Digital temperature controller and display
- Adjustable PVC coated shelves
- 4 sides Double glass
- Cooling system on top
- Maintenance free condenser
- Ventilated cooling system
- Automatic defrost

Options:

- Lockable Door
- Adjustable chrome plated shelves

Standard Features:

- Bright internal LED illumination on 4 sides
- Digital temperature controller and display
- Adjustable chrome plated shelves
- 4 sides double glass
- Maintenance free condenser
- Ventilated cooling system
- Automatic defrost
- Adjustable feet
- Stainless steel

Standard Features:

- Bright internal LED illumination on 2 sides
- Digital temperature controller and display
- Rotational chrome plated shelves
- 4 sides double Glass
- Adjustable feet
- Maintenance free condenser
- Ventilated cooling system
- Automatic defrost

FCD07-80V		FCD07-78BV8		FCD07-108BV	
Capacity-Gross (L)	80	Capacity-Gross (L)	78	Capacity-Gross (L)	108
Temperature Range (°C)	0-12	Temperature Range (°C)	0-12	Temperature Range (°C)	0-12
Rated Input Power (W)	160/142	Rated Input Power (W)	180	Rated Input Power (W)	230
Refrigerant	R134a/R600a	Refrigerant	R134a/R600a	Refrigerant	R134a/R600a
Type of Climate	N	Type of Climate	N	Type of Climate	N
N.W. (kg)	37.5	N.W. (kg)	45.5	N.W. (kg)	52
G.W. (kg)	39.5	G.W. (kg)	48	G.W. (kg)	54
Overall Dimension (mm)	385x375x1040	Overall Dimension (mm)	430x390x986	Overall Dimension (mm)	470x470x870
Package Dimension (mm)	435x435x1085	Package Dimension (mm)	500x460x1010	Package Dimension (mm)	560x530x938
20"Container	130	20"Container	112	20"Container	88
40"Container	260	40"Container	230	40"Container	176
40"Container (high)	260	40"Container (high)	230	40"Container (high)	176
Color	white/black/silver/red			Color	black/stainlss steel

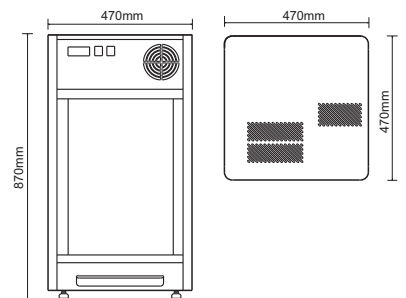
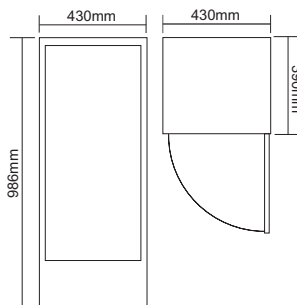
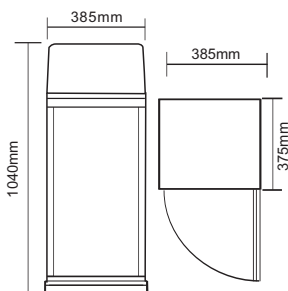

Standing Display Refrigerator



FCD07-500AV

Standard Features:

- Bright internal LED illumination on sides
- Digital temperature controller and display
- Adjustable PVC coated shelves
- Front flat glass door
- 4 sides double glass
- 4 Castors, 2 with brakes
- Ventilated cooling system
- Automatic defrost

Options:

- Adjustable chrome plated shelves
- Lockable door

FCD07-500AV

Capacity-Gross (L)	500
Temperature Range (°C)	0-12
Rated Input Power (W)	580
Refrigerant	R404a
Type of Climate	N
N.W. (kg)	135
G.W. (kg)	144
Overall Dimension (mm)	650x650x1945
Package Dimension (mm)	735x735x1980
20"Container	24
40"Container	48
40"Container (high)	48
Coior	white/black/silver/red

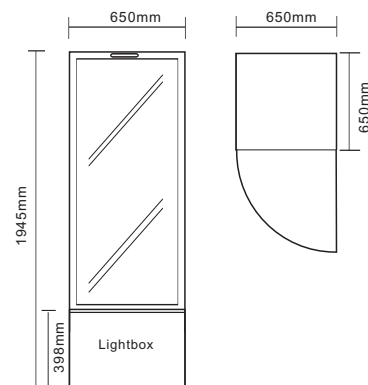

Standing Display Refrigerator



FCD07-270BV



FCD07-270BA

Standard Features:

- Bright internal LED illumination under each sheleve
- Digital temperature controller and display
- Adjustable chrome plated shelves
- Ventilated cooling system
- Automatic defrost
- 4 Castors, 2 with brakes
- Triple glass



Adjustable Shelf



Digital Controller



Adjustable Angles

FCD07-270BV

Capacity-Gross (L)	270
Temperature Range (°C)	2-8
Rated Input Power (W)	410
Refrigerant	R134a/R600a
Type of Climate	N
N.W. (kg)	163.5
G.W. (kg)	172
Overall Dimension (mm)	915x675x1268.5
Package Dimension (mm)	965x725x1310
20"Container	17
40"Container	36
40"Container (high)	36

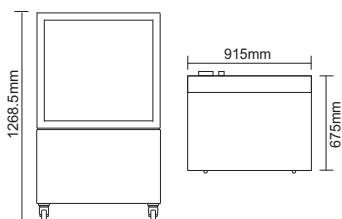

FCD07-270BA

Capacity-Gross (L)	270
Temperature Range (°C)	2-8
Rated Input Power (W)	410
Refrigerant	R134a/R600a
Type of Climate	N
N.W. (kg)	163.5
G.W. (kg)	172
Overall Dimension (mm)	915x675x1275
Package Dimension (mm)	965x725x1310
20"Container	17
40"Container	36
40"Container (high)	36

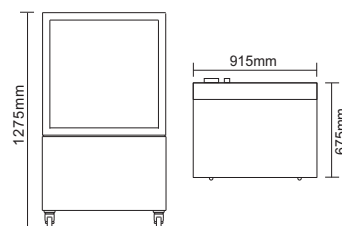

Open Display



FCD07-180BV



FCD07-220BV



FCD07-220BV2

Standard Features:

- Bright internal LED illumination each shelf
- Digital temperature controller and display
- Stainless steel shelves
- 4 Castors with 2 brakes
- 2 Sides safety glass
- With night curtain
- Ventilated cooling system
- Automatic defrost
- Stainless steel



LED Lights



With Curtain



Digital Controller



Castors

FCD07-220BV2: Additional back evaporator, cool enough for dairy product.

FCD07-180BV		FCD07-220BV		FCD07-220BV2	
Capacity-Gross (L)	180	Capacity-Gross (L)	220	Capacity-Gross (L)	220
Temperature Range (°C)	2-10	Temperature Range (°C)	2-10	Temperature Range (°C)	2-6
Rated Input Power (W)	1340	Rated Input Power (W)	1340	Rated Input Power (W)	1340
Refrigerant	R404a	Refrigerant	R404a	Refrigerant	R404a
Max.ambient Temp./RH	28°C/70%	Max.ambient Temp./RH	28°C/70%	Max.ambient Temp./RH	28°C/70%
N.W. (kg)	96	N.W. (kg)	106	N.W. (kg)	121
G.W. (kg)	100	G.W. (kg)	111	G.W. (kg)	127
Overall Dimension (mm)	600x494x1450	Overall Dimension (mm)	600x494x1740	Overall Dimension (mm)	670x512x1792
Package Dimension (mm)	666x560x1510	Package Dimension (mm)	666x560x1808	Package Dimension (mm)	740x585x1860
20"Container	36	20"Container	36	20"Container	30
40"Container	72	40"Container	72	40"Container	60
40"Container (high)	72	40"Container (high)	72	40"Container (high)	60

FCD07-180BV Dimensions		FCD07-220BV Dimensions		FCD07-220BV2 Dimensions	
	600mm		600mm		670mm
	600mm		600mm		670mm
	494mm		494mm		512mm
	1450mm		1740mm		1792mm

Countertop Display Refrigerator



RF100-107



RF100-108

Model	RF100-107	RF100-108
Description	Countertop Display Refrigerator	Countertop Display Refrigerator
Volts	220~240V/50Hz	220~240V/50Hz
Power (W)	290	450
Capacity (L)	180	300
Shelves	2	2
Temperature Range	2~8°C	2~8°C
Dimensions (mm)	810x650x775	650x805x1245
N.W. (kg)	78	125
Certificate	CE	CE

Countertop Display Refrigerator



RF100-109



RF100-110

Model	RF100-109	RF100-110
Description	Countertop Display Refrigerator	Countertop Display Refrigerator
Volts	220~240V/50Hz	220~240V/50Hz
Power (W)	450	450
Capacity (L)	400	500
Shelves	2	2
Temperature Range	2~8°C	2~8°C
Dimensions (mm)	900x805x1245	1200x805x1245
N.W. (kg)	141	163
Certificate	CE	CE

Open Display

Model: FCD06-122G2B

Dimensions : 1220*760*1980

Volume : 950L

Temperature : +10~0°C

Refrigerant : R134a

Refrigeration : Fan cooling

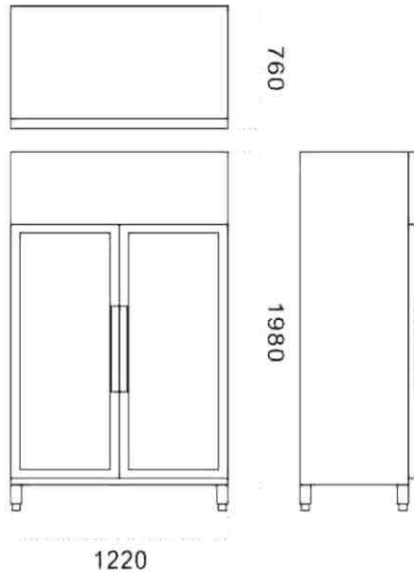

Model: FCD06-122G4B

Dimensions : 1220*760*1980

Volume : 950L

Temperature : +10~0°C

Refrigerant : R134a

Refrigeration : Fan cooling

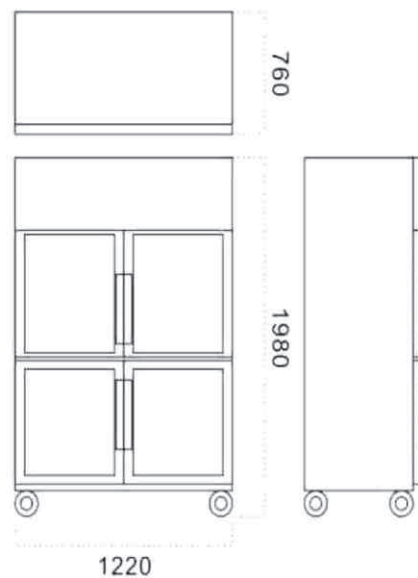

Salad Showcase



FCD07-1/4X5

Standard Features:

- Digital temperature controller and display
- 4 sides glass
- Direct cooling system
- Automatic defrost
- 5X1/4 GN plate
- Stainless steel



FCD07-1/3X4

Standard Features:

- Digital temperature controller and display
- 4 sides glass
- Direct cooling system
- Automatic defrost
- 4X1/3 GN plate
- Stainless steel

FCD07-1/4X5

Capacity-Gross (L)	5x1/4 GN
Temperature Range (°C)	0-12
Rated Input Power (W)	140/110
Refrigerant	R134a/R600a
Type of Climate	4
N.W. (kg)	34.8
G.W. (kg)	38
Overall Dimension (mm)	1200x335x225
Package Dimension (mm)	1275x410x330
20"Container	154
40"Container	315
40"Container (high)	368

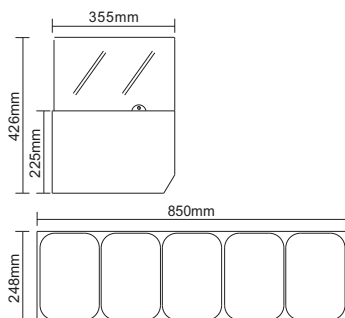

FCD07-1/3X4

Capacity-Gross (L)	4x1/3 GN
Temperature Range (°C)	0-12
Rated Input Power (W)	140/110
Refrigerant	R134a/R600a
Type of Climate	4
N.W. (kg)	40.5
G.W. (kg)	42.5
Overall Dimension (mm)	1200x395x225
Package Dimension (mm)	1275x470x330
20"Container	140
40"Container	294
40"Container (high)	336

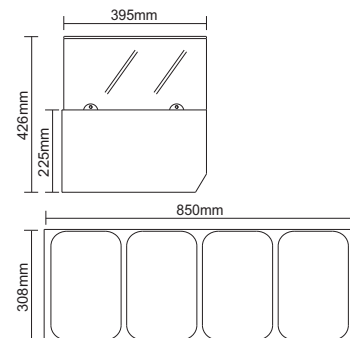

Salad Showcase



FCD07-1/4X7

Standard Features:

- Digital temperature controller and display
- 4 sides glass
- Direct cooling system
- Automatic defrost
- 7X1/4 GN plate
- Stainless steel



FCD07-1/3X6

Standard Features:

- Digital temperature controller and display
- 4 sides glass
- Direct cooling system
- Automatic defrost
- 6X1/3 GN plate
- Stainless steel

FCD07-1/4X7

Capacity-Gross (L)	7x1/4 GN
Temperature Range (°C)	0-12
Rated Input Power (W)	157/125
Refrigerant	R134a/R600a
Type of Climate	4
N.W. (kg)	43.5
G.W. (kg)	45.5
Overall Dimension (mm)	1500x335x225
Package Dimension (mm)	1575x410x330
20"Container	119
40"Container	252
40"Container (high)	288

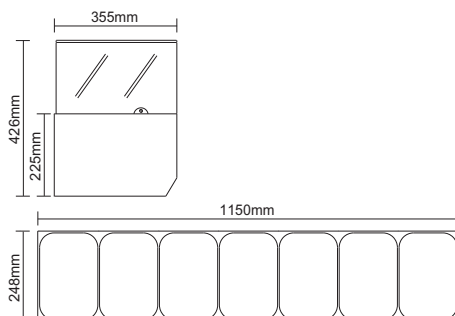

FCD07-1/3X6

Capacity-Gross (L)	6x1/3 GN
Temperature Range (°C)	0-12
Rated Input Power (W)	157/125
Refrigerant	R134a/R600a
Type of Climate	4
N.W. (kg)	45.8
G.W. (kg)	48
Overall Dimension (mm)	1500x395x225
Package Dimension (mm)	1575x470x330
20"Container	105
40"Container	217
40"Container (high)	248

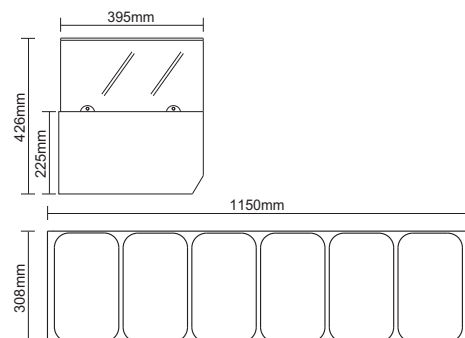

Sushi Showcase



Option:

Light box for advertisement

Model	RF100-179	RF100-180
Description	Sushi Showcase	Sushi Showcase
Volts	220~240V/50Hz	220~240V/50Hz
Power (W)	160	160
Class mate	3	S/S #304
Refrigerant	R134a/R600a	R134a/R600a
Temperature Range	0~12°C	0~12°C
Capacity-gross	6*1/3GN plate	5*1/2GN plate
Dimensions (mm)	1483x450x330	1754x450x330
N.W. (kg)	39	44
Certificate	CE	CE

Sushi Showcase



RF100-174

Standard Features:

- Bright internal LED illumination on top
- Digital temperature controller and display
- Front curved glass
- Sliding doors
- Direct cooling system
- Automatic defrost
- Top evaporator with basin to collect condensation
- GN pan can be ordered.



RF100-175

Standard Features:

- Bright internal LED illumination on top
- Digital temperature controller and display
- Front curved glass
- Sliding doors
- Direct cooling system
- Automatic defrost
- Top evaporator with basin to collect condensation
- GN pan can be ordered.

RF100-174

Capacity-Gross (L)	4*1/3 GN plate
Temperature Range (°C)	0-12
Rated Input Power (W)	125
Refrigerant	R134a/R600a
Type of Climate	4
N.W. (kg)	34.5
G.W. (kg)	36.5
Overall Dimension (mm)	1177x420x265
Package Dimension (mm)	1267x510x360
20"Container	114
40"Container	246
40"Container (high)	287

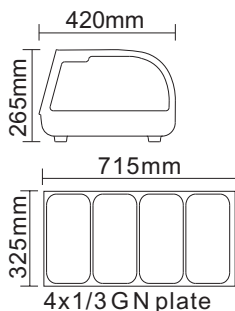

RF100-175

Capacity-Gross (L)	5*1/3 GN plate
Temperature Range(°C)	0-12
Rated Input Power (W)	135
Refrigerant	R134a/R600a
Type of Climate	4
N.W. (kg)	38.5
G.W. (kg)	40.5
Overall Dimension (mm)	1352x420x265
Package Dimension (mm)	1443x510x360
20"Container	96
40"Container	192
40"Container (high)	224

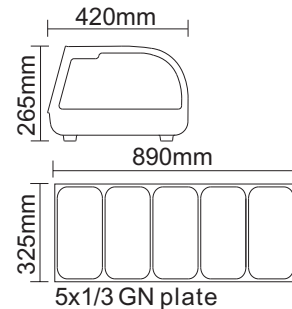

Sushi Showcase



RF100-176

Standard Features:

- Bright internal LED illumination on top
- Digital temperature controller and display
- Front curved glass
- Sliding doors
- Direct cooling system
- Automatic defrost
- Top evaporator with basin to collect condensation
- GN pan can be ordered.



RF100-177

Standard Features:

- Bright internal LED illumination on top
- Digital temperature controller and display
- Front curved glass
- Sliding doors
- Direct cooling system
- Automatic defrost
- Top evaporator with basin to collect condensation
- GN pan can be ordered.

RF100-176

Capacity-Gross (L)	6*1/3 GN plate
Temperature Range (°C)	0-12
Rated Input Power (W)	145
Refrigerant	R134a/R600a
Type of Climate	4
N.W. (kg)	41.5
G.W. (kg)	44
Overall Dimension (mm)	1529x420x265
Package Dimension (mm)	1619x510x360
20"Container	84
40"Container	180
40"Container (high)	210

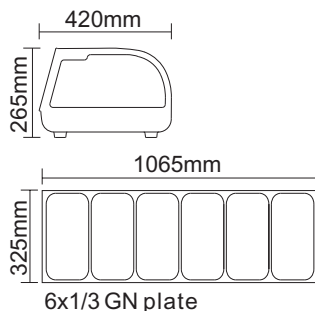

RF100-177

Capacity-Gross (L)	5*1/2 GN plate
Temperature Range (°C)	0-12
Rated Input Power (W)	160/180
Refrigerant	R134a/R600a
Type of Climate	4
N.W. (kg)	45
G.W. (kg)	49
Overall Dimension (mm)	1800x420x265
Package Dimension (mm)	1890x510x360
20"Container	78
40"Container	162
40"Container (high)	188

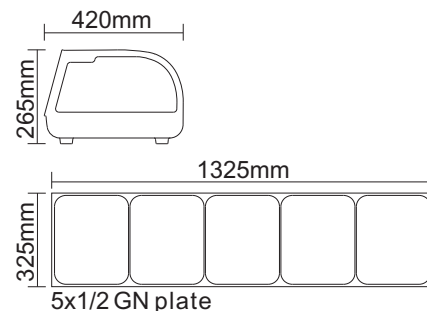

Cold Showcase



FCD02-530V

Model	FCD02-530V	FCD02-540V	FCD02-550V
Description	Countertop Cold Deli Showcase	Countertop Cold Deli Showcase	Countertop Cold Deli Showcase
Volts	220~240V/50Hz	220~240V/50Hz	220~240V/50Hz
Power (W)	420	550	570
Capacity (L)	140	190	240
Shelves	2	2	2
Temperature Range	2~8°C	2~8°C	2~8°C
Dimensions (mm)	900x540x790	1200x540x790	1500x540x790
N.W. (kg)	90	115	120
Certificate	CE	CE	CE

Cold Showcase



FCD02-A550V2

Model	FCD02-A530V2	FCD02-A540V2	FCD02-A550V2
Description	Countertop Cold Deli Showcase	Countertop Cold Deli Showcase	Countertop Cold Deli Showcase
Volts	220~240V/50Hz	220~240V/50Hz	220~240V/50Hz
Power (W)	485	598	626
Capacity (L)	192	260	330
Shelves	3	3	3
Temperature Range	2~8°C	2~8°C	2~8°C
Dimensions (mm)	900x540x930	1200x540x930	1500x540x930
N.W. (kg)	140	170	199
Certificate	CE	CE	CE

Cold Showcase

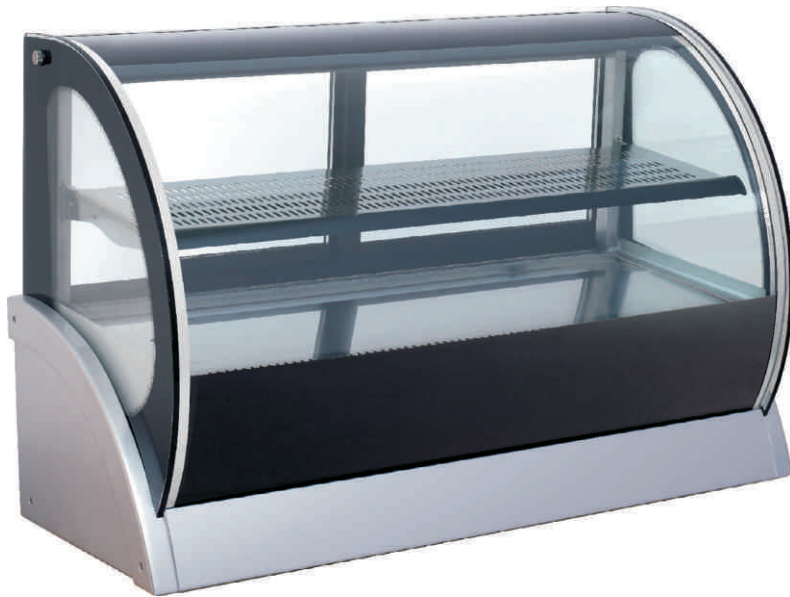

FCD02-S540A

Model	FCD02-S530A	FCD02-S540A	FCD02-S550A
Description	Countertop Cold Deli Showcase	Countertop Cold Deli Showcase	Countertop Cold Deli Showcase
Volts	220~240V/50Hz	220~240V/50Hz	220~240V/50Hz
Power (W)	420	550	570
Capacity (L)	115	155	200
Shelves	2	2	2
Temperature Range	2~8°C	2~8°C	2~8°C
Dimensions (mm)	900x540x790	1200x540x790	1500x540x790
N.W. (kg)	90	115	120
Certificate	CE	CE	CE

Cold Showcase



FCD02-550A

Model	FCD02-530A	FCD02-540A	FCD02-550A
Description	Countertop Cold Deli Showcase	Countertop Cold Deli Showcase	Countertop Cold Deli Showcase
Volts	220~240V/50Hz	220~240V/50Hz	220~240V/50Hz
Power (W)	420	550	570
Capacity (L)	70	94	118
Shelves	2	2	2
Temperature Range	2~8°C	2~8°C	2~8°C
Dimensions (mm)	900x530x820	1200x530x820	1500x530x820
N.W. (kg)	90	115	120
Certificate	CE	CE	CE

Cold Showcase



FCD03-540V

Model	FCD03-530V	FCD03-540V	FCD03-550V
Description	Countertop Cold Deli Showcase	Countertop Cold Deli Showcase	Countertop Cold Deli Showcase
Volts	220~240V/50Hz	220~240V/50Hz	220~240V/50Hz
Power (W)	421	487	573
Capacity (L)	140	190	240
Shelves (pans)	4	5	7
Temperature Range	-15~-20°C	-15~-20°C	-15~-20°C
Dimensions (mm)	900x540x790	1200x540x790	1500x540x790
N.W. (kg)	90	115	120
Certificate	CE	CE	CE

Cake Display



RF100-100



RF100-112

Model	RF100-100	RF100-112
Description	Cake Display	Cake Display
Volts	220~240V/50Hz	220~240V/50Hz
Power(W)	480	180
Capacity(L)	400	100
Shelves	4 (Glass)	3 (Glass)
Temperature Range	2~8°C	2~8°C
Dimensions (mm)	680x680x1750	480x480x1030
N.W.(kg)	125	38
Certificate	CE	CE

Remarks: Bright internal LEDs on sides
Round double glass
Automatic defrost



Standing Display Refrigerator



RF100-103



RF100-104

Model	RF100-103	RF100-104
Description	Display Refrigerator	Display Refrigerator
Volts	220~240V/50Hz	220~240V/50Hz
Power(W)	410	410
Capacity(L)	370	370
Shelves	2	2
Temperature Range	2~8°C	2~8°C
Dimensions(mm)	1215x675x1269	1215x675x1269
N.W.(NJ)	183	183
Certificate	CE	CE

Standing Display Refrigerator



RF100-105



RF100-106

Model	RF100-105	RF100-106
Description	Display Refrigerator	Display Refrigerator
Volts	220~240V/50Hz	220~240V/50Hz
Power(W)	410	410
Capacity(L)	470	470
Shelves	2	2
Temperature Range	2~8°C	2~8°C
Dimensions(mm)	1500x730x1160	1500x730x1160
N.W.(NJ)	204	204
Certificate	CE	CE

Showcase



Model	RF100-111
Description	Showcase
Volts	220~240V/50Hz
Power(W)	110
Capacity(L)	67
Temperature Range	2~12°C
Dimensions(mm)	767x612x328
N.W.(NJ)	25
Certificate	CE

Display Cooler





RF101-100



RF101-101



RF101-102

Model	RF101-100	RF101-101	RF101-102
Description	Display Cooler	Display Cooler (with fan inside and back)	Display Cooler
Capacity (L)	21	21	15
Volts	220~240V/110V 50/60Hz	220~240V/110V 50/60Hz	220~240V/110V 50/60Hz
Power (W)	76	76	76
Refrigerant	R134a/36g	R134a/36g	R134a/35g
Temperature Range	0~10°C	0~10°C	0~10°C
Dimensions (mm)	330x410x472	330x410x472	350x420x360
Certificate			

Absorption Refrigerator



RF180-103



RF180-104

Model	RF180-103	RF180-104
Description	Absorption Refrigerator	Absorption Refrigerator
Volts	65	65
Power(W)	110V/60Hz 230V/50Hz	110V/60Hz 230V/50Hz
Door Type	Solid Door	Glass Door
Capacity(L)	30	30
Temperature Range	0~8℃	4~12℃
Color	Matt Black/Dark Gray/ Creamy White (Can Be Customized)	Matt Black/Dark Gray/ Creamy White (Can Be Customized)
Power Consumption	0.85KW.h/24H	1KW.h/24H
Dimensions(mm)	420x400x480	415x400x480
N.W.(kg)	13.2	15.2
Certificate	CE	CE

Absorption Refrigerator



RF180-101



RF180-102



RF180-100



Model	RF180-101	RF180-102	RF180-100
Description	Absorption Refrigerator	Absorption Refrigerator	Absorption Refrigerator
Volts	65	65	80
Power(W)	110V/60Hz 230V/50Hz	110V/60Hz 230V/50Hz	110V/60Hz 230V/50Hz
Door Type	Solid Door	Glass Door	Solid Door
Capacity(L)	40	40	50
Temperature Range	0~8℃	4~12℃	0~8℃
Color	Matt Black/Dark Gray/ Creamy White (Can Be Customized)	Matt Black/Dark Gray/ Creamy White (Can Be Customized)	Matt Black
Power Consumption	0.85KW.h/24H	1KW.h/24H	1KW.h/24H
Dimensions(mm)	440x400x550	435x400x550	510x550x430
N.W.(kg)	14.8	17	18.2
Certificate	CE	CE	CE

Absorption Refrigerator



RF180-105



RF180-106

Model	RF180-105	RF180-106
Description	Absorption Refrigerator	Absorption Refrigerator
Volts	80	80
Power(W)	110V/60Hz 230V/50Hz	110V/60Hz 230V/50Hz
Door Type	Solid Door	Glass Door
Capacity(L)	60	60
Temperature Range	0~8℃	4~12℃
Color	Matt Black/Dark Gray/ Creamy White (Can Be Customized)	Matt Black/Dark Gray/ Creamy White (Can Be Customized)
Power Consumption	1.15KW.h/24H	1.15KW.h/24H
Dimensions(mm)	500x485x560	495x485x560
N.W.(kg)	18.5	20.8
Certificate	CE	CE

Cool Display



RF100-113



RF100-114

Standard Features:

- Bright internal LED illumination on top
- Digital temperature controller and display
- Double glass
- Automatic closing door
- Adjustable PVC coated shelf
- Adjustable feet
- Frost free defrost system
- Automatic defrost
- With overall polyurethane foam

RF100-113	
Capacity-Gross (L)	49
Temperature Range (°C)	2-8
Rated Input Power (W)	130
Refrigerant	R134a
Type of Climate	4
N.W. (kg)	40
G.W. (kg)	42
Overall Dimension (mm)	570x533x530
Package Dimension (mm)	630x593x590
20"Container	81
40"Container	171
40"Container (high)	228

RF100-114	
Capacity-Gross (L)	99
Temperature Range (°C)	2-8
Rated Input Power (W)	150
Refrigerant	R134a
Type of Climate	4
N.W. (kg)	46
G.W. (kg)	48.5
Overall Dimension (mm)	570x550x730
Package Dimension (mm)	630x610x790
20"Container	54
40"Container	114
40"Container (high)	171

Cool Display



RF100-115



RF100-116

Standard Features:

- Bright internal LED illumination on top
- Digital temperature controller and display
- Double glass
- Automatic closing door
- Adjustable PVC coated shelf
- Adjustable feet
- Frost free defrost system
- Automatic defrost
- With overall polyurethane foam

RF100-115	
Capacity-Gross (L)	49
Temperature Range (°C)	2-8
Rated Input Power (W)	150
Refrigerant	R134a
Type of Climate	4
N.W. (kg)	43
G.W. (kg)	45
Overall Dimension (mm)	620x543x690
Package Dimension (mm)	680x603x750
20"Container	81
40"Container	171
40"Container (high)	171

RF100-116	
Capacity-Gross (L)	99
Temperature Range (°C)	2-8
Rated Input Power (W)	150
Refrigerant	R134a
Type of Climate	4
N.W. (kg)	50
G.W. (kg)	53
Overall Dimension (mm)	620x560x890
Package Dimension (mm)	680x620x950
20"Container	54
40"Container	114
40"Container (high)	114

Cool Display



RF100-117



RF100-118

Standard Features:

- Bright internal LED illumination on top
- Digital temperature controller and display
- Double glass
- Automatic closing door
- Adjustable PVC coated shelf
- Adjustable feet
- Frost free defrost system
- Automatic defrost
- With overall polyurethane foam

RF100-117	
Capacity-Gross (L)	91
Temperature Range (°C)	2-12
Rated Input Power (W)	200
Refrigerant	R134a
Type of Climate	4
N.W. (kg)	59
G.W. (kg)	63
Overall Dimension (mm)	910× 510× 550
Package Dimension (mm)	980× 580× 600
20"Container	60
40"Container	129
40"Container (high)	172

RF100-118	
Capacity-Gross (L)	101
Temperature Range (°C)	2-12
Rated Input Power (W)	230
Refrigerant	R134a
Type of Climate	4
N.W. (kg)	58
G.W. (kg)	63
Overall Dimension (mm)	805× 410× 703
Package Dimension (mm)	875× 480× 753
20"Container	83
40"Container	189
40"Container (high)	189

Cool Display



Standard Features:

- Bright internal LED illumination on sides
- Digital temperature controller and display
- Cooling system on top
- 4 adjustable glass shelves
- Front flat glass door
- 4 sides double glass
- 4 castors, 2 with brakes
- On / Off Switch
- Ventilated cooling system
- Automatic defrost

RF100-119

RF100-119	
Capacity-Gross (L)	450
Temperature Range (°C)	2-8
Rated Input Power (W)	480
Refrigerant	R134a
Type of Climate	6
N.W. (kg)	163
G.W. (kg)	186
Overall Dimension (mm)	656x653x1892
Package Dimension (mm)	756x753x2012
20" Container	21
40" Container	45
40" Container(high)	45

Standing Display Refrigerator



RF100-120



RF100-121

- Bright internal LED illumination on sides
- Digital temperature controller and display
- Adjustable chrome plated shelves
- Front flat glass door
- 4 sides triple glass
- 4 castors, 2 with brakes
- On / Off Switch
- Ventilated cooling system
- Automatic defrost
- Stainless Steel



Digital Controller



LED Lights



Castors

RF100-120	
Capacity-Gross (L)	270
Temperature Range°C	0-10
Rated Input Power(W)	420
Refrigerant	R134
Type of Climate	6
N.W.(kg)	140
G.W.(kg)	165
Overall Dimension(mm)	650× 650× 1500
Package Dimension(mm)	749× 749× 1530
20"Container	21
40"Container	45
40"Container(high)	45

RF100-121	
Capacity-Gross (L)	350
Temperature Range°C	0-10
Rated Input Power(W)	420
Refrigerant	R134
Type of Climate	6
N.W.(kg)	152
G.W.(kg)	165
Overall Dimension(mm)	850× 650× 1500
Package Dimension(mm)	949× 749× 1530
20"Container	18
40"Container	36
40"Container	36

Standing Display Refrigerator



RF100-122



RF100-123

Standard Features:

- Bright internal LED illumination on sides
- Digital temperature controller and display
- Adjustable chrome plated shelves
- Front flat glass door
- 4 sides triple glass
- 4 castors, 2 with brakes
- On/Off switch
- Ventilated cooling system
- Automatic defrost
- Stainless Vteel



Digital Controller



LED Lights



Castors

RF100-122	
Capacity-Gross (L)	400
Temperature Range °C	0-10
Rated Input Power(W)	420
Refrigerant	R134
Type of Climate	6
N.W.(kg)	175
G.W.(kg)	205
Overall Dimension(mm)	650×650×1908
Package Dimension(mm)	749×749×1930
20"Container	21
40"Container	45
40"Container(high)	45

RF100-123	
Capacity-Gross (L)	550
Temperature Range °C	0-10
Rated Input Power(W)	420
Refrigerant	R134
Type of Climate	6
N.W.(kg)	192
G.W.(kg)	227
Overall Dimension(mm)	850×650×1908
Package Dimension(mm)	949×749×1930
20"Container	18
40"Container	36
40"Container(high)	36

Refrigerated Showcase



RF100-124



RF100-125

Standard Features:

- Bright internal LED illumination on the top
- Digital temperature control and display
- Top evaporator with basin to collect condensation
- Direct cooling system
- Automatic defrost
- Single glass
- Front curved glass
- Sliding door
- Trolley optional
- GN pan can be ordered.

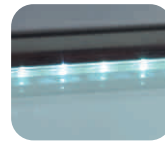

LED Lights



Digital Controller

RF100-124	
Capacity-Gross (L)	175
Temperature Range (°C)	2-12
Rated Input Power (W)	200
Refrigerant	R134a/R600a
Type of Climate	N
N.W. (kg)	66
G.W. (kg)	70
Overall Dimension (mm)	890×890×542/1080
Package Dimension(mm)	960×960×668
20"Container	30
40"Container	72
40"Container (high)	96

RF100-125	
Capacity-Gross (L)	255
Temperature Range (°C)	2-12
Rated Input Power (W)	200
Refrigerant	R134a/R600a
Type of Climate	N
N.W. (kg)	84
G.W. (kg)	88
Overall Dimension (mm)	1250×890×542/1080
Package Dimension (mm)	1300×960×668
20"Container	27
40"Container	63
40"Container (high)	84

Countertop Displays



RF100-126

Standard Features:

- Digital temperature controller and display
- Automatic defrost
- Direct cooling system
- Stainless Steel
- Folding complete glass cover
- On/off switch
- Adjustable feet



RF100-127

Standard Features:

- Digital temperature controller and display
- Automatic defrost
- Direct cooling system
- Single tempered glass
- Stainless steel base panel



Digital Controller

RF100-126

Capacity-Gross (L)	118
Temperature Range (°C)	2-12
Rated Input Power (W)	110/105
Refrigerant	R134a/R600a
Type of Climate	4
N.W. (kg)	38.5
G.W. (kg)	41
Overall Dimension (mm)	695*882*417
Package Dimension (mm)	775*955*490
20" Container	56
40" Container	112
40" Container (high)	140

RF100-127

Capacity-Gross (L)	128
Temperature Range (°C)	2-12
Rated Input Power (W)	110/105
Refrigerant	R134a/R600a
Type of Climate	4
N.W. (kg)	42
G.W. (kg)	45
Overall Dimension (mm)	685*874*419
Package Dimension (mm)	775*955*490
20" Container	56
40" Container	112
40" Container (high)	140

Countertop Displays



RF100-178

Standard Features:

- Digital temperature controller and display
- Automatic defrost
- Direct cooling system
- Single tempered glass
- Stainless steel base panel

RF100-178	
Capacity-Gross (L)	40
Temperature Range °C	2-12
Rated Input Power (W)	110/105
Refrigerant	R134a/R600a
Type of Climate	4
N.W.(kg)	25
G.W.(kg)	27
Overall Dimension (mm)	680*575*335
Package Dimension (mm)	730*650*400
20" Container	120
40" Container	255
40" Container (high)	306

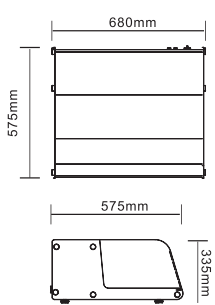

Countertop Displays



RF100-129

Standard Features:

- Bright internal LED illumination on the top
- Temperature controller and display
- Adjustable chrome plated shelves
- 4 sides double glass
- Sliding doors
- Ventilated cooling system
- Automatic defrost
- Stainless steel
- 2 Bracket levels for adjusting the angle of the shelf



RF100-130



LED Lights



Adjustable Shelf



Digital Controller

RF100-129	
Capacity-Gross (L)	130
Temperature Range°C	0-12
Rated Input Power (W)	230/200
Refrigerant	R134a/R600a
Type of Climate	4
N.W.(kg)	66
G.W.(kg)	68
Overall Dimension(mm)	797× 590× 685
Package Dimension(mm)	873× 642× 735
20"Container	60
40"Container	132
40"Container(high)	132

RF100-130	
Capacity-Gross (L)	201
Temperature Range°C	0-12
Rated Input Power (W)	375
Refrigerant	R134a
Type of Climate	4
N.W.(kg)	84.5
G.W.(kg)	87
Overall Dimension(mm)	1217× 590× 685
Package Dimension(mm)	1293× 642× 735
20"Container	36
40"Container	81
40"Container(high)	81

Open Displays



RF100-131



RF100-132

Standard Features:

- Bright internal LED illumination each shelf Digital
- Temperature controller and display
- Stainless steel shelves
- 4 Castors with 2 brakes
- 2 Sides with safety glass
- With night curtain
- Ventilated cooling system
- Automatic defrost
- Stainless steel



LED Lights



With Curtain



Digital Controller



Castors

RF100-131	
Capacity-Gross (L)	200
Temperature Range°C	2-10
Rated Input Power (W)	1340
Refrigerant	R404a
Type of Climate	6
N.W.(kg)	115
G.W.(kg)	121
Overall Dimension(mm)	1000× 560× 1250
Package Dimension(mm)	1075× 635× 1310
20"Container	19
40"Container	40
40"Container(high)	40

RF100-132	
Capacity-Gross (L)	1900
Temperature Range°C	2-10
Rated Input Power (W)	800
Refrigerant	R404a
Type of Climate	6
N.W.(kg)	96
G.W.(kg)	105
Overall Dimension(mm)	780× 700× 1473
Package Dimension(mm)	840× 760× 1520
20"Container	19
40"Container	40
40"Container(high)	40

Open Displays



RF100-133

Standard Features:

- Bright internal LED lighting on top and each shelf
- Digital temperature controller and display
- 4 castors with 2 brakes
- Side single tempered glass
- With night curtain
- Ventilated cooling system
- Automatic defrost
- Filter mesh in front of the base
- Adjustable shelves
- Condensator at back side, free maintenance

OPTION: Light Box On Top



RF100-134

Standard Features:

- Bright internal LED lighting at 2 front sides
- Digital temperature controller and display
- 4 castors with 2 brakes
- Double tempered glass
- With night curtain
- Ventilated cooling system
- Automatic defrost
- Filter mesh in front of the base
- Adjustable shelves
- Condensator at back side, free maintenance

RF100-133	
Capacity-Gross (L)	360
Temperature Range (°C)	2-10
Rated Input Power (W)	1400
Refrigerant	R404a
Type of Climate	6
N.W. (kg)	125
G.W. (kg)	145
Overall Dimension (mm)	876*945*1520
Package Dimension (mm)	1020*940*1570
20" Container	12
40" Container	24
40" Container (high)	24

RF100-134	
Capacity-Gross (L)	390
Temperature Range (°C)	2-10
Rated Input Power (W)	1400
Refrigerant	R404a
Type of Climate	6
N.W. (kg)	123
G.W. (kg)	143
Overall Dimension (mm)	920*847*1510
Package Dimension (mm)	990*920*1580
20" Container	12
40" Container	24
40" Container (high)	24

Open Displays



RF100-135



RF100-136

Standard Features:

- Bright internal LED lighting on top and bottom
- Digital temperature controller and display
- 4 castors with 2 brakes
- Double tempered glass
- With night curtain
- Ventilated cooling system
- Automatic defrost
- Filter mesh in front of the base
- Adjustable shelves
- Condensator at back side, free maintenance



LED Lights



With Curtain



Digital Controller



Castors

RF100-135	
Capacity-Gross (L)	230
Temperature Range (°C)	2-10
Rated Input Power (W)	1340
Refrigerant	R404a
Type of Climate	6
N.W. (kg)	82
G.W. (kg)	102
Overall Dimension (mm)	600*890*1520
Package Dimension (mm)	660*950*1590
20"Container	20
40"Container	41
40"Container (high)	41

RF100-136	
Capacity-Gross (L)	380
Temperature Range (°C)	2-10
Rated Input Power (W)	1400
Refrigerant	R404a
Type of Climate	6
N.W. (kg)	107
G.W. (kg)	129
Overall Dimension (mm)	1000*890*1520
Package Dimension (mm)	1060*950*1590
20"Container	12
40"Container	24
40"Container (high)	24

Open Displays



RF100-137



RF100-138

Standard Features:

- Bright internal LED illumination under each shelf
- Digital temperature control and display
- Stainless steel shelves
- 4 castors with 2 brakes
- Tempered glass
- Stainless steel louver
- With curtain
- Ventilated cooling system
- Automatic defrost

RF100-137	
Capacity-Gross (L)	435
Temperature Range (°C)	2-10
Rated Input Power (W)	2650
Refrigerant	R404a
Max.ambient Temp./RH	27°C/70%
N.W. (kg)	137
G.W. (kg)	155
Overall Dimension (mm)	762x765x2070
Package Dimension (mm)	792x795x2100
20"Container	14
40"Container	28
40"Container (high)	28

RF100-138	
Capacity-Gross (L)	530
Temperature Range (°C)	2-10
Rated Input Power (W)	2650
Refrigerant	R404a
Max.ambient Temp./RH	27°C/70%
N.W. (kg)	154
G.W. (kg)	175
Overall Dimension (mm)	915× 765× 2070
Package Dimension (mm)	945× 795× 2100
20"Container	14
40"Container	28
40"Container (high)	28

Salad Showcase



RF100-141



RF100-142

Standard Features:

- Digital temperature control and display
- With overall polyurethane foam
- Glass cover with electric heating film
- Bright internal LED illumination on top and bottom
- Ventilated cooling system

RF100-141

Capacity-Gross (L)	122
Temperature Range°C	-18~-22
Rated Input Power (W)	660
Refrigerant	R134a
Type of Climate	4
N.W.(kg)	162
G.W.(kg)	170
Overall Dimension(mm)	1220x680x740
Package Dimension(mm)	1270x730x790
20"Container	24
40"Container	54
40"Container(high)	81

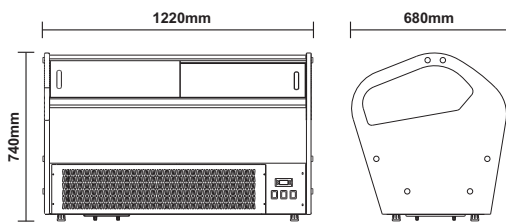

RF100-142

Capacity-Gross (L)	142
Temperature Range°C	-18~-22
Rated Input Power (W)	660
Refrigerant	R134a
Type of Climate	4
N.W.(kg)	167
G.W.(kg)	175
Overall Dimension(mm)	1420x680x740
Package Dimension(mm)	1470x730x790
20"Container	20
40"Container	44
40"Container(high)	66

